

LCD 用コネクタ

56-ENG-1640

Connector for LCD

取り扱い説明書

Manual

適用製品：9240 シリーズ

Application product: series 9240

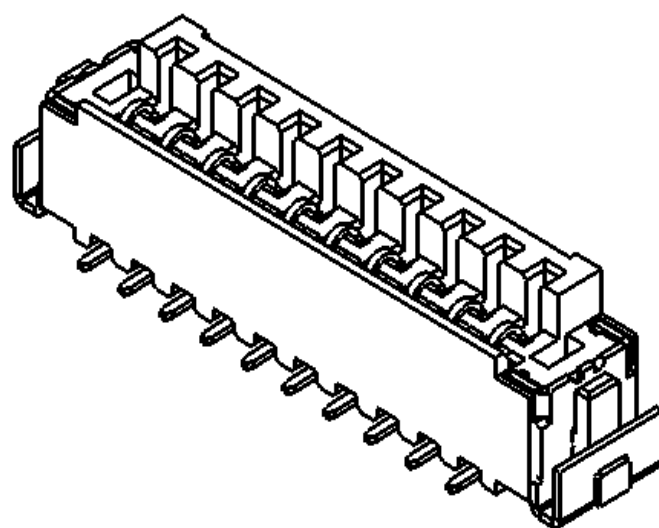

使用上の注意点 / Instructions and directions for use

1) 端子形状 / Terminal form

コネクタに嵌合する端子は下図寸法のものを使用し、端子先端にはC0.05の面取り加工を施すことを推奨致します。面取り加工が追加出来ない場合は先端にバリが無いものをご使用下さい。バリがある状態で嵌合しますと端子変形やハウジング削れによる接触不良等の原因となります。

Please insert terminal in the connector by the size of the figure below. The point of terminal recommends the chamfering processing of C0.05mm. Please use the one that there is no Barr in the point when the chamfering cannot be processed. It may cause poor contact due to deformation of terminals or rubbing of the housing.

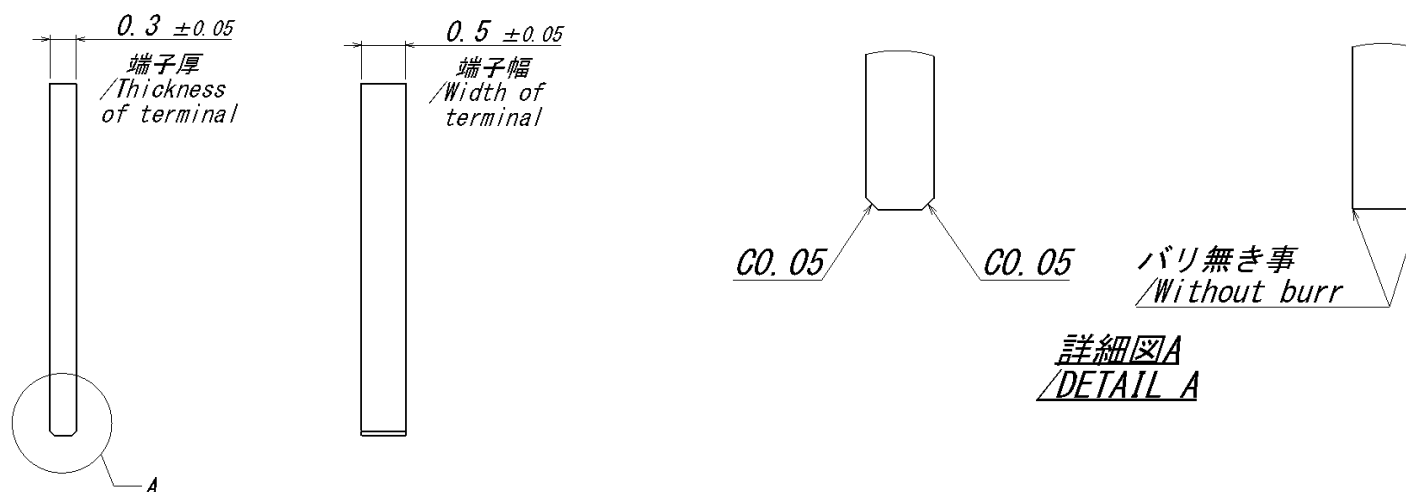

2) 嵌合角度 / Insert angle

端子変形やハウジング削れによる接触不良等を防止するため、コネクタに対しLCDパネルを下図で示す角度以下で誘い込み及び嵌合を行って下さい。なお、誘い込み角度とは最初の位置決め角度であり、嵌合可能な角度ではありません。

Please guide and insert the LCD panel to the connector at an angle or less as shown in below Figure to prevent poor contact due to terminal deformation or scraping of the housing. Guiding angle is initial location angle. It is not the angle to insert.



図1/Figure 1

誘い込み角度/ Guiding angle

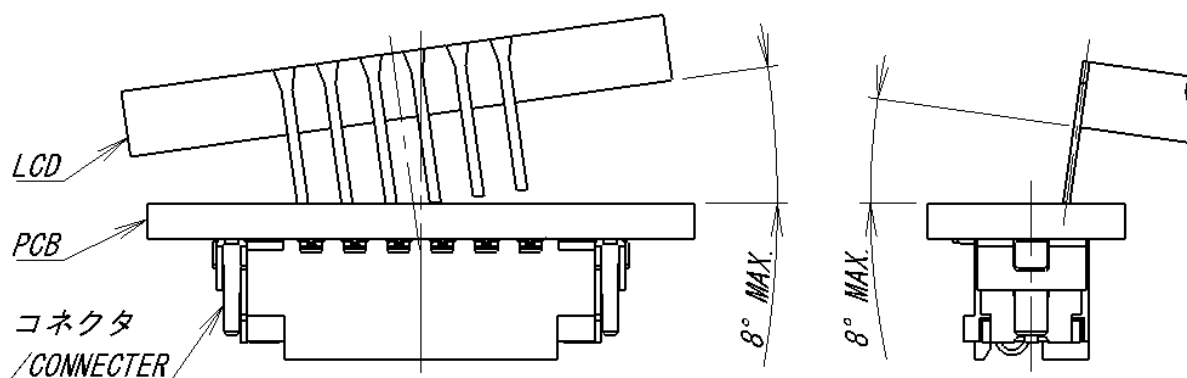

図2/Figure 2

嵌合角度/ Inserting angle

LCD 用连接器

56-ENG-1640

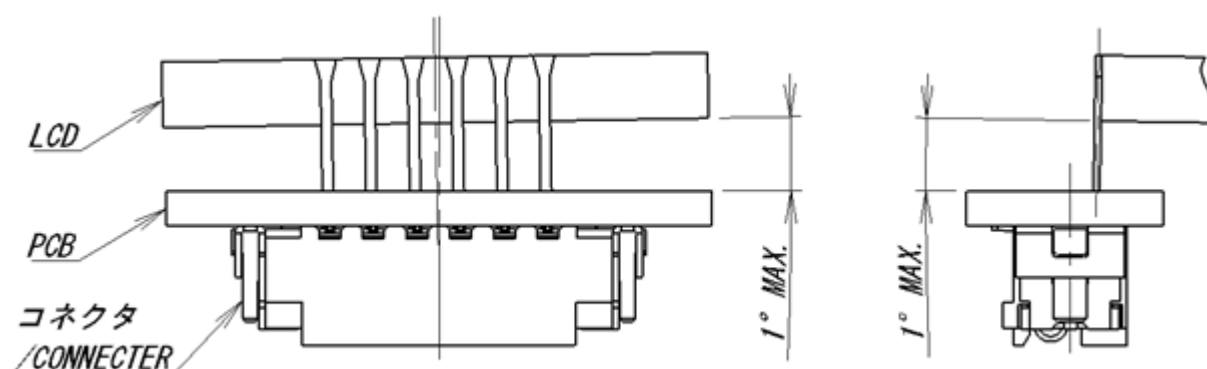
Connector for LCD

使用说明书

Manual

适用产品：9240 系列

Application product: series 9240

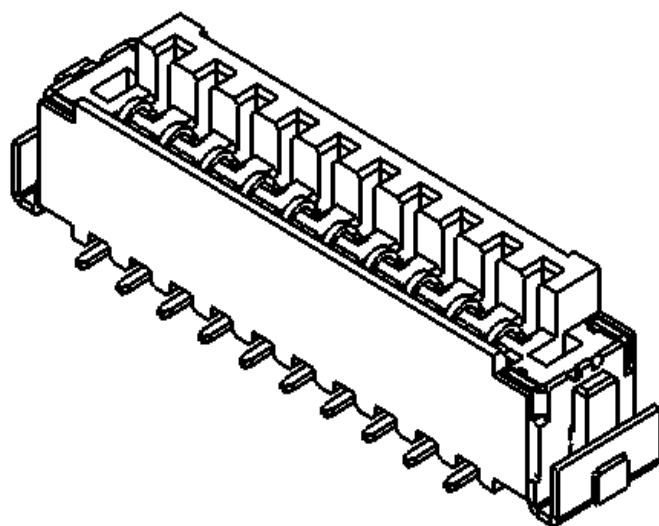

使用上的注意点 / Instructions and directions for use

1) 端子形状 / Terminal form

建议使用下图所示尺寸的连接器安装端子，并用 C0.05 对端子尖端进行倒角。如果无法添加倒角，请使用尖端上没有毛刺的倒角。如果安装有毛刺，可能会因外壳刮伤而导致端子变形或接触不良。

Please insert terminal in the connector by the size of the figure below. The point of terminal recommends the chamfering processing of C0.05mm. Please use the one that there is no Burr in the point when the chamfering cannot be processed. It may cause poor contact due to deformation of terminals or rubbing of the housing.

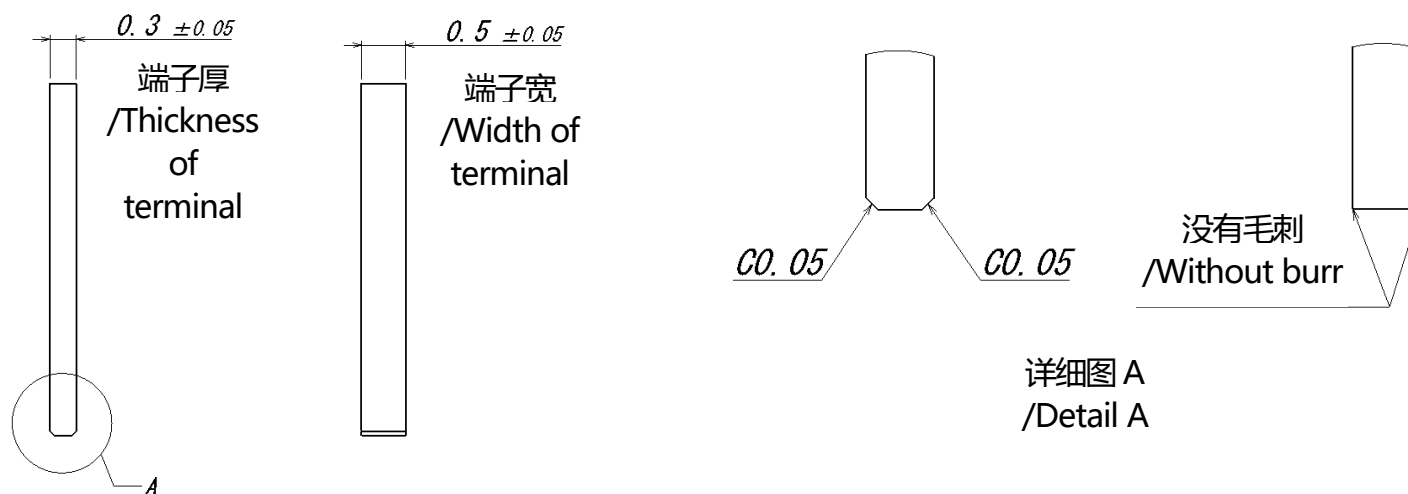

2) 嵌合角度 / Insert angle

为了防止由于端子变形或外壳刮伤而导致接触不良，如下图所示，将 LCD 面板以一定角度或更小角度安装到连接器上。引入角度是初始定位角，不是嵌合可能角度。

Please guide and insert the LCD panel to the connector at an angle or less as shown in below Figure to prevent poor contact due to terminal deformation or scraping of the housing. Guiding angle is initial location angle. It is not the angle to insert.

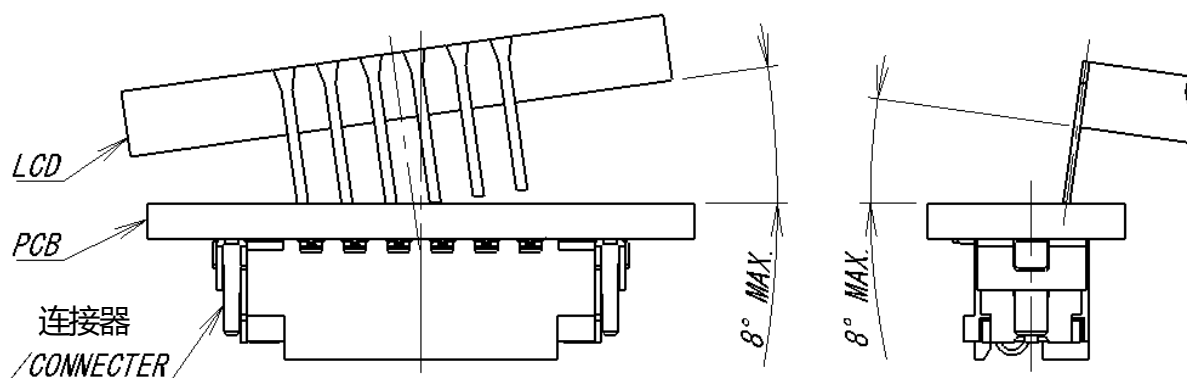

图 1/ Figure 1
引入角度 / Guiding angle

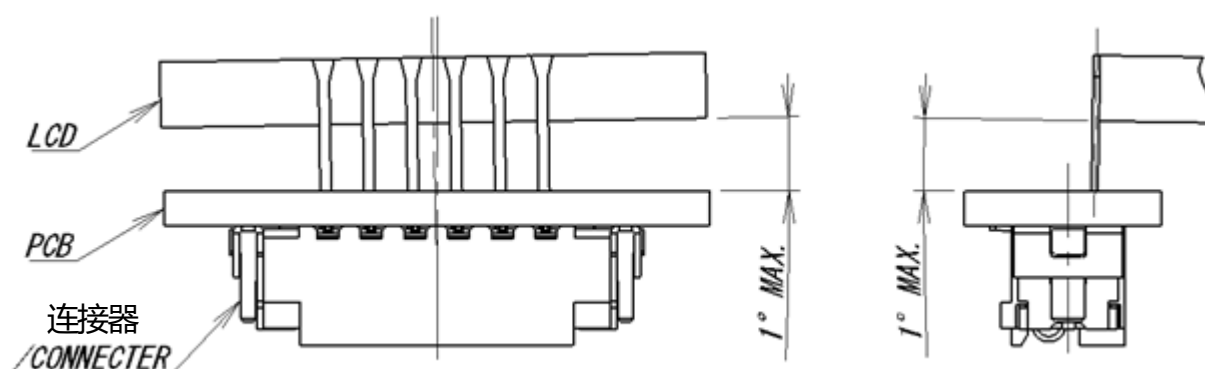

图 2/ Figure 2
嵌合角度 / Inserting angle